

C&I Hybrid Cooling ESS Warranty Terms (Oversea)

Document Version 01

Release Date 2025-1-10

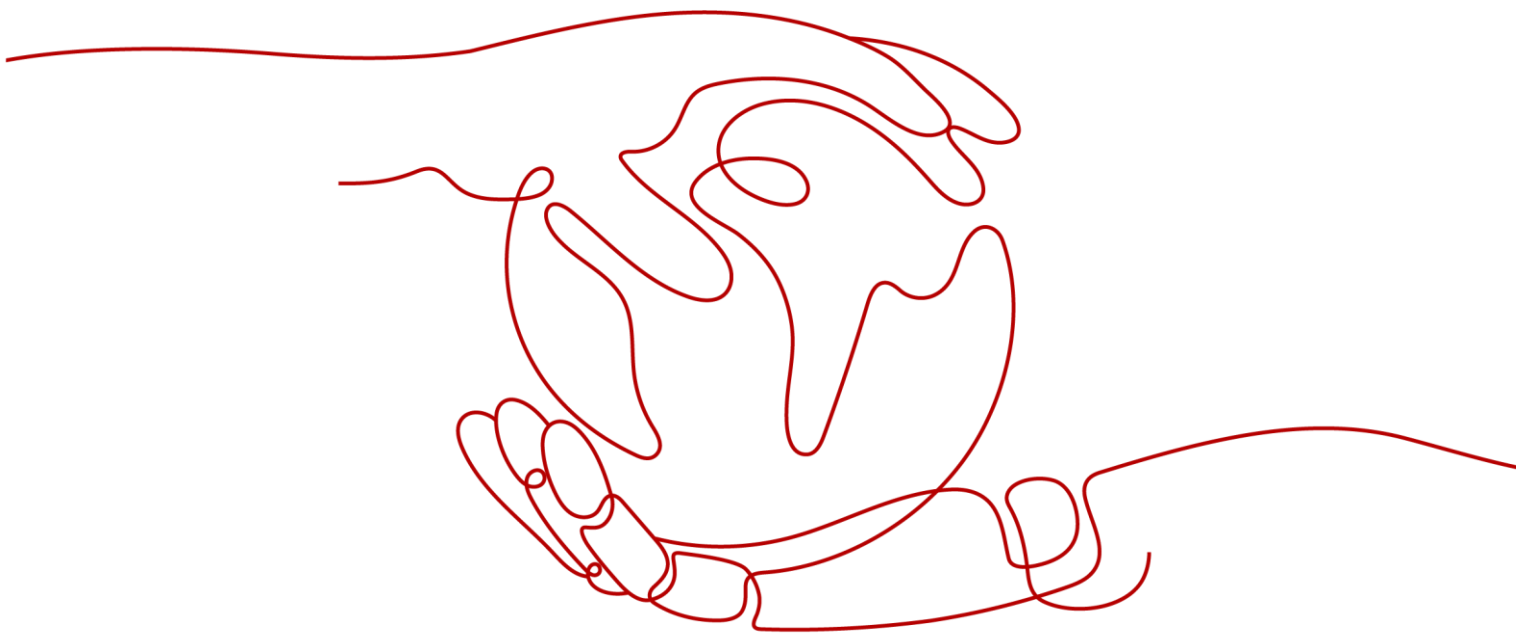



Copyright © Huawei Technologies Co., Ltd. 【2024】 . All rights reserved.

No part of this document may be reproduced or transmitted in any form or by any means without prior written consent of Huawei Technologies Co., Ltd.

Trademark Notice



HUAWEI is trademark or registered trademark of Huawei Technologies Co., Ltd.

Other trademarks, product, service and company names mentioned are the property of their respective owners.

General Disclaimer

The information in this document may contain predictive statements including, without limitation, statements regarding the future financial and operating results, future product portfolio, new technology, etc. There are a number of factors that could cause actual results and developments to differ materially from those expressed or implied in the predictive statements. Therefore, such information is provided for reference purpose only and constitutes neither an offer nor an acceptance. Huawei may change the information at any time without notice.

In case the warranty conditions in this Document are inconsistent with the sales contracts between the Buyer and Huawei, the terms in the sales contracts shall prevail.

修订记录

日期	修订版本	描述	作者	评审人
2024/12/10	Draft	Draft	Liangkang 、 weizheng	Liuqianghua 、 Peichenzhi、 Chenyong、 Taopengtian 、 Weizheng、 Liangkang、 Luhaiyang、 Huangxin、 Zhangtenglong、 Zhangruoyu 、 Wangli and other members of the service extension team
2025/01/10	Official version	Official version	Liangkang 、 weizheng	Liuqianghua 、 Peichenzhi、 Chenyong、 Taopengtian 、 Weizheng、 Liangkang、 Luhaiyang、 Huangxin、 Zhangtenglong、 Zhangruoyu 、 Wangli and other members of the service extension team





Contents

Contents	5
1 Applicable Product Model.....	6
2 Warranty Scope	7
2.1 Performance guarantee	7
2.2 Product warranty	7
3 Warranty Period Description.....	11
3.1 General Description of Warranty Period	11
3.2 Warranty Service Description	12
4 Warranty clauses.....	15
4.1 Basic Clauses	15
4.2 Exemption Clauses	16

1 Applicable Product Model

- LUNA2000-215-2S10

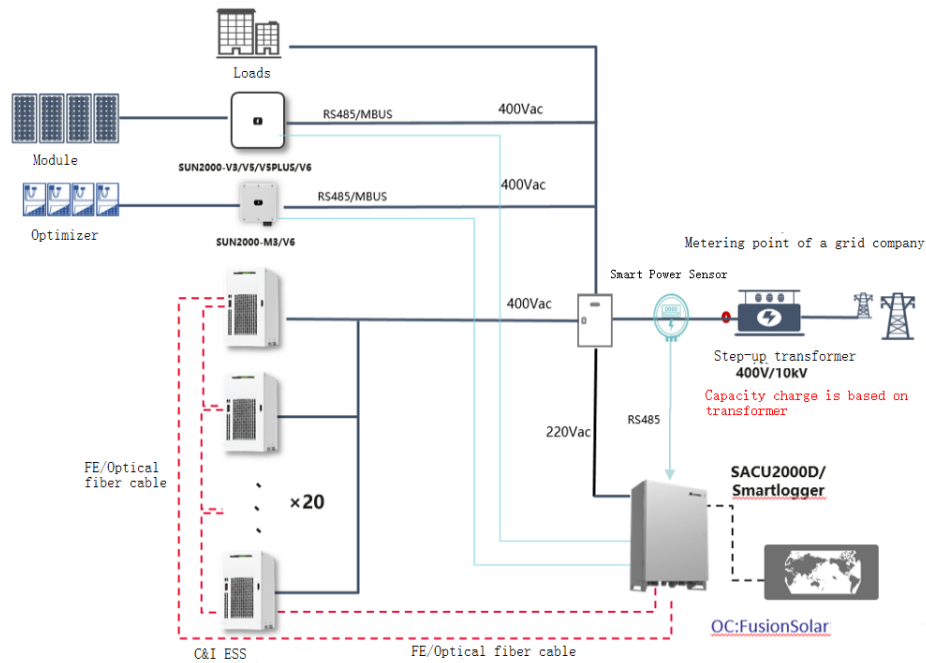

Huawei C&I Hybrid Cooling Energy Storage System(ESS for short) are applicable to commercial and industrial scenarios. It work with SACU or SmartLogger. The SmartPCS is connected to the Rack Controller Moudule , and charges batteries when the power grid is sufficient. When the power grid needs to be output, the SmartPCS outputs the stored battery energy to loads for use.

2 Warranty Scope

2.1 Performance guarantee

Performance guarantee defined for the ESS: 100% DOD, 60% capacity at EOL, operating temperature range of $-30^{\circ}\text{C}\sim+40^{\circ}\text{C}$, The number of cycles is defined according to the working conditions of each area. For details, see Table 2-1.

ESS's warranty includes product warranty and performance guarantee, which are provided separately. The product warranty period does not affect the battery performance guarantee. The battery module performance guarantee period and the battery module product warranty period are aligned. The battery module performance guarantee period and the number of cycles, whichever comes first, triggers the over-warranty. PCS, DCDC, rack control module, and liquid cooling units only involve the product warranty period and have nothing to do with battery performance.

Capacity test conditions: At an ambient temperature of $25^{\circ}\text{C}\pm 3^{\circ}\text{C}$, fully discharge the batteries, charge them to 100% SOC at a rate of 0.5CP, discharge them to end-of-discharge SOC at a rate of 0.5CP, Record the average SOH value. The amount of electricity released during the process.

The ESS is required to be connected to Huawei PV Cloud and be remotely upgraded to the latest firmware version in a timely manner to ensure battery life. For products that have been disconnected from the Internet for more than 6 months or have not been connected to Huawei PV Cloud, Huawei cannot continue to provide advanced warranty. This product is subject to the warranty end time of the basic warranty service.

Warranty standards for typical working conditions of industrial and commercial liquid-cooled energy storage systems are as follows:

Table 2-1 Performance guarantee standards for the ESS under typical working conditions

Region	Model	Pack Quantity	Ambient Temperature	Charge/ Discharge Rate	Number of Cycles @ 60% SOH	Standard Working Conditions
Outside of China	LUNA200 0-215- 2S10	4	-30°C to $+40^{\circ}\text{C}$	0.5CP	7300	Number of cycles per day ≤ 2

2.2 Product warranty

The ESS product warranty is classified into basic warranty and advanced warranty. After devices are delivered, both of them are automatically obtained. For products that have been disconnected from the network for more than six months or have not been connected to the FusionSolar SmartPVMS, Huawei



will not continue to provide the advanced warranty service. The warranty of the products will expire at the end time of the basic warranty service.

For devices that do not connect to the FusionSolar SmartPVMS, you can purchase Huawei's 5-year (10-years for Europe) Preventive Maintenance to obtain the advanced warranty.

Table 2-2 Basic warranty period of each product series (year)

Category	Sub-device	Europe	China	Middle East and Central Asia	Asia Pacific	Latin America	Southern Africa	Northern Africa	Class B
Devices	Smart String Energy Storage System ESS	2	2	2	2	2	2	2	2
Auxiliary products	SACU/SmartLogger	1	1	1	2	1	1	1	1

The following auxiliary materials and mechanical parts are not covered by the warranty:

Category	Description
Consumables	Including but not limited to cables, door locks, lamps
Cables	Cables between cabinets
Mechanical parts	Including but not limited to battery holder and other mechanical parts
Accessories for battery cabinets	Including but not limited to cabinet mechanical parts, documents, product accessories, installation accessories, and tools

Table 2-3 Advanced warranty period of each product series (year)

Category	Device	Europe	Middle East and Central Asia	Asia Pacific	Latin America	Southern Africa	Northern Africa	Class B
Devices	Smart String ESS	8	3	3	3	3	3	3
Auxiliary products	SACU/SmartLogge	1	1	0	1	1	1	1

The following auxiliary materials and mechanical parts are not covered by the warranty:

Category	Description
Consumables	Including but not limited to cables, door locks, lamps
Cables	Cables between cabinets
Mechanical parts	Including but not limited to battery installation racks and other mechanical parts
Accessories for battery cabinets	Including but not limited to cabinet mechanical parts, documents, product accessories, installation accessories, and tools

Table 2-4 Warranty period start dates

Warranty period start dates
shipment date + 90 days, or the date when Huawei receives the service request, whichever is earlier

NOTE

1. If the warranty period of equipment starts from the shipment date, this item must be specified in the contract.
2. For channel sales projects, channel partners must complete necessary ESS capability certification.
3. For channel distribution projects, channel partners are responsible for notifying customers of technical requirements such as transportation, storage, site selection, installation space, and foundation construction requirements. Such content must be included in the contract. Huawei will not be responsible for any problems caused by ignorance of the preceding requirements.
4. The spare parts of the ESS are replaced by parts replacement, which does not affect the warranty period of the entire system.
5. The warranty period of spare parts such as the SmartLogger complies with the original rules of the region.
6. Warranty Service policies are differentiated based on the environment where energy storage devices are located. The deployment must meet at least the C4 environment, not the distance from the sea. For details about site selection, installation, and maintenance of energy storage devices in C1 to C4, see the user manual, quick guide, and maintenance manual. In addition, the warranty service is provided.
7. The ESS can be installed in C5 environment, which only provides a 5-year warranty service and can't extend the warranty. It must be purchased with a mandatory paint inspection and active replacement package during the life cycle; paint inspection: cabinet inspection, and paint isolated rusted areas.
8. Liquid cooling energy storage is deployed in the C5 scenario. Direct sales are not distributed.
9. In the C5 scenario, the cabinet gap needs to be expanded for maintenance and painting. The cabinet spacing requirements are as follows: 1 m from the back of the cabinet to the firewall, 0.6 m from left to right, and 0.6 m from back to back of the cabinet.
10. In the C5 scenario, a maximum of five-year standard warranty service is provided for ESS devices. (2 Yr Basic Warranty + 3 Yr Advanced Warranty) 5 years extended warranty service. The service life of the product is increased by 5 years from the service life of the product (standard warranty + extended warranty).
11. In the C5 scenario, it is recommended that the service life of a product not exceed the service life committed by Huawei. If the service life of a product exceeds the service life committed by Huawei, Huawei shall not be liable for any device problem.
12. In the C5 scenario, all energy storage devices must be connected to HUAWEI CLOUD.
13. Within the battery cabinet lifecycle, the following services must be configured: inspection and paint repair service, 5-year proactive component replacement package, and 10-year proactive component replacement package.

Table 2-5 Basic Warranty Service Content

Category	Service	SLA Description
Remote technical support	Hotline service	24x7 The SLA signed in the contract is subject to the Digital Power global service hotline. https://digitalpower.huawei.com/en/contact.html
	Remote troubleshooting	China/Japan/South Korea: 12x7 Other countries: 9x5
	Online technical support	24x7
Software support	Software update authorization	24x7



Hardware support	Advance spare parts replacement (Non-dangerous goods)	9x5x2BD-S (Japan: 9x5x2BD)
	Advance spare parts replacement (Dangerous goods)	9x5x2BD-S (Japan: 9x5x2BD) In countries or regions that do not support spare parts delivery for dangerous goods (batteries and fire cylinders with extinguishant), the spare parts response time must be specified separately in the contract. For details about the spare parts delivery time, confirm with the regional spare parts contact person. For details, see the following SLA policy table .

NOTE

- 24x7: Monday to Sunday, 00:00–24:00
- 12x7: Monday to Sunday, 8:00 to 20:00 (all days, all holidays)
- 9x5: business days, 9:00–18:00, excluding public holidays
- The basic warranty does not include onsite services, which need to be purchased separately.

Table 2-6 Regional lithium battery spare parts service SLA strategy

Reginal	Europe	Japan	Middle East and Central Asia	Asia Pacific	Latin America	Southern Africa	Northern Africa	Class B
Battery Spare parts	2BD-S**	2BD-S	No Commitment	2BD-S**	2BD-S**	2BD-S**	No commitment	No commitment

NOTE

- BD: Business Day
- 2BD-S: Huawei ships spare parts within two business days after confirming the necessity of hardware replacement and receiving the RMA information.
- **: 2BD-S can be promised in 12 European countries (Czech, France, Germany, Italy, Netherlands, Poland, Slovakia, Spain, Türkiye, Switzerland, UK, and Ireland), 10 Latin American countries (Paraguay, Uruguay, Brazil, Guatemala, Jamaica, Nicaragua, Dominican Republic, Mexico, Chile, and Peru), five Asia-Pacific countries (Indonesia, Thailand, Malaysia, Singapore, and Philippines), and South Africa.
- The preceding table is for reference only since the dangerous goods capability is being built. Regions and rep offices need to confirm the local SLA capability with the local spare parts platform. The specific capability is subject to the frontline evaluation.

3 Warranty Period Description

3.1 General Description of Warranty Period

Warranty period start dates: shipment date + 90 days, or the date when Huawei receives the service request, whichever is earlier

For the ESS continuously connected to the FusionSolar SmartPVMS, a 5, 10-year(Except for Europe) extended warranty service package can be provided for customers after the warranty period expires. If the ESS is not continuously connected to the FusionSolar SmartPVMS, customers must purchase the preventive Maintenance service of the same period before purchasing the extended warranty service.

The extended warranty does not include spare parts replacement at the end of the 10-year warranty period. If the extended warranty needs to be extended to more than 10 years, the customer needs to purchase a 10-year proactive parts replacement package and replace the parts. The customer shall be responsible for the faults caused by delayed replacement.

In principle, the product warranty period must be continuous from the date of purchase. Otherwise, extension warranty is not supported.

The warranty extension time of each sub-component is as follows:

Table 3-1: Basic extended warranty period of each product series (years)									
Category	Device	Europe	Japan	Middle East and Central Asia	Asia Pacific	Latin America	Southern Africa	Northern Africa	Class B
Devices	Smart String ESS	5	5、10	5、10	5、10	5、10	5、10	5、10	5、10
Auxiliary products	SmartLogger	Identical warranty periods as those of the ESSs are supported.							

3.2 Warranty Service Description

3.2.1 Overall situation

basic extended warranty service package for industrial and commercial energy storage products is as follows:

Category	Service	SLA Description
Remote technical support	Hotline service	24x7 The SLA signed in the contract is subject to the Digital Power global service hotline. https://digitalpower.huawei.com/en/contact.html
	Remote troubleshooting	China/Japan/South Korea: 12x7 Other countries: 9x5
	Online technical support	24x7
Software support	Software update authorization	24x7
Hardware support	Advance spare parts replacement (Non-dangerous goods)	9x5x2BD-S (Japan: 9x5x2BD)
	Advance spare parts replacement (Dangerous goods)	9x5x2BD-S (Japan: 9x5x2BD) In countries or regions that do not support spare parts delivery for dangerous goods (batteries and fire cylinders with extinguishant), the spare parts response time must be specified separately in the contract. For details about the spare parts delivery time, confirm with the regional spare parts contact person. For details, see the SLA policy table .

3.2.2 Spare parts service description:

- By default, the C&I hybrid cooling ESS products support parts replacement.
- The functionality of the spare parts provided by Huawei is not lower than that of the faulty parts. Do not promise that all spare parts are new or completely the same as the original ones.
- Parts: parts other than the entire system
- The basic extended warranty does not include onsite services. If onsite troubleshooting is required, customers need to purchase onsite services separately.
- The following auxiliary materials and mechanical parts are not covered by the warranty. For details about the warranty list, see the spare parts list.

Type	Description
Consumables	Including but not limited to cables, door locks, lamps, and batteries (small batteries other than battery packs)
Cables	Cables between cabinets



Type	Description
Mechanical parts	Including but not limited to battery racks and mechanical parts
ESS cabinet accessories	Including but not limited to cabinet mechanical parts, documents, product accessories, installation accessories, and tools

3.2.3 Remote Support Service

Remote support means that Huawei provides technical consultation or troubleshooting solutions for Huawei products by phone or email. It includes hotline, remote technical support, and online technical support.

Online technical support allows the Buyer to acquire maintenance experience, cases, and technical support information of Huawei products by visiting the Huawei technical support website (<https://support.huawei.com/enterprise/en/category/fusionsolar-pid-1600073963553>).

Hotline

Hotline is a telephonic service interface and platform for receiving and tracking service requests of the Buyer.

Hotline: <https://digitalpower.huawei.com/en/contact.html>

Service email: <https://digitalpower.huawei.com/en/contact.html>

Remote Technical Support

Remote technical support includes technical consultation and troubleshooting. Technical consultation service provides consultation on issues not related to product faults. Troubleshooting service provides the Buyer with solutions to fix problems within the period specified in the SLA.

Online Technical Support

Online technical support allows the Buyer to acquire maintenance experience, cases, and technical support information of Huawei products by visiting the Huawei technical support website (<https://support.huawei.com/enterprise/en/category/fusionsolar-pid-1600073963553>).

Multi-Channel Support

Customers can follow official accounts of Huawei Digital Power across various media platforms to access more technical support information.

3.2.4 Software Support Service

During the warranty period, Huawei ensures that the product works properly. Nevertheless, Huawei does not guarantee that the software will be error-free or run uninterruptedly, nor does it guarantee that all program errors will be rectified.

Huawei provides software releases. During the warranty period, the Buyer can obtain new software releases for free from the following website. It is important to note that the software releases provided by Huawei are intended to fix functional defects and do not offer new functions and/or features.

<https://support.huawei.com/enterprise/en/fusionsolar/luna2000c-pid-255740933/software>



Each software release shall be valid for 3.5 years from its release date. After the validity period, Huawei does not provide troubleshooting and fixing services to such software release. Before the expiry of the validity period, the Buyer needs to update to the newer software release. If the Buyer does not update to the newer software release, it is deemed that the Buyer waives the right to software updates. Huawei will not be responsible for any issues related to the old software release arising in such cases.

3.2.5 Hardware Support Service

Hardware devices are the prerequisite for the stable running of the ESS. Huawei's hardware support service ensures the stable running of customers' devices.

4 Warranty clauses

4.1 Basic Clauses

During the warranty period, Huawei promise as follows:

4. 1. 1 Provide replacement service when normal functions cannot be used due to defects in materials, manufacturing or workmanship.
4. 1. 2 Provide replacement service when normal functions cannot be used due to non-compliance with published product specifications.
4. 1. 3 Huawei spare parts (excluding batteries) shall be delivered within two working days after the service request is confirmed. After receiving the spare parts, the asset ownership of the faulty parts will be transferred to Huawei. The customer shall return the faulty parts to Huawei within 15 working days. If the faulty parts cannot be returned, the customer must compensate Huawei for the loss.
4. 1. 4 If Huawei provides spare parts in the order, the customer is not allowed to sell the spare parts to third parties or use them for other purposes.
4. 1. 5 Spare parts provided by Huawei are equivalent to those used by customers on site.
4. 1. 6 After Huawei provides spare parts, the system warranty period inherits or is not shorter than the warranty period in the original contract.
4. 1. 7 Onsite engineering operations are completed by the customer, and Huawei is not responsible for onsite replacement.
4. 1. 8 After the spare parts request is confirmed, Huawei is responsible for the transportation of spare parts within the warranty period.
4. 1. 9 If a product fault is found within the warranty scope, the customer should contact Huawei hotline to report the fault and provide the following information:
 1. Brief description of the fault, including but not limited to input and output parameters, alarm ID, cause ID, and run logs.
 2. Product serial number.
 3. Purchase receipt.

The above information is the condition for reporting faults.

- 4.1.10 If the customer does not provide sufficient information or the spare parts are replaced without Huawei's confirmation when the actual equipment is free of fault, the customer shall bear the freight.

4.2 Exemption Clauses

- 4.2.1. The preceding support services are only applicable to Huawei-produced equipment. The hardware equipment beyond the agreed scope is not covered by Huawei's service scope.
- 4.2.2. In all cases, whether on the basis of contract, warranty, tort (including liability for fault and strict liability) or any other theory and legal claim, Huawei does not assume any liability for any consequences arising from the installation, use, or poor performance of its products, any indirect loss, collateral damage, or punitive damages arising from any defect or breach of warranty, including, but not limited to, loss of profits, damage to goodwill or business reputation, or loss of delay. The total amount of Huawei's responsibility for damages or otherwise shall not exceed the purchase price paid by the original Buyer for the Products.
- 4.2.3. Huawei commercial and industrial energy storage systems have a two-year basic warranty by default. A advanced warranty can be provided only when they are connected to Huawei PV cloud or purchasing for five-year(ten-year in Europe) Preventive Maintenance.If the customer fails to connect to Huawei management system for more than six months, Huawei has the right to cancel the advanced warranty.
- 4.2.4. Widely used vulnerable parts and consumables are not covered by Huawei's service scope.
- 4.2.5. If Huawei cannot fulfill the service commitment within the promised time due to non-Huawei reasons, the customer shall exempt Huawei from the SLA fulfillment responsibilities and relevant compensations. If on-site services are required, travel time shall be excluded from SLA time.
- 4.2.6. Faults caused by the following reasons are not covered by Huawei's service scope:
- Damages to Huawei devices due to force majeure, such as natural disasters, fires, and wars
 - Damages to Huawei devices due to normal wear and tear
 - Direct damages caused by failure to comply with the written requirements on the operating environment or external electrical specifications
 - AC or DC connectors broken, damaged, or burnt due to the poor engineering quality of the connectors
 - Damages caused by lightning due to improper system design
 - Large-scale damages to Huawei hardware or data due to customer's negligence, improper operation, or intentional sabotage
 - Damages caused by customer's failure to transport, store, install and operate Huawei products in accordance with the user manuals
 - ESS performance degradation caused by leaving idle batteries uncharged for 6 months or longer, or battery cell damages caused by leaving batteries uncharged for extended periods, which will not be covered by the warranty
 - Damages caused by improper operation or failure to comply with the temperature requirements during transportation or operation
 - Damages caused by maintenance or other services performed by personnel not authorized by Huawei



- System damages caused by improper operations of a third party or customer, including system migration and installation performed in violation of Huawei's requirements, and adjustment, alteration, and removal of identification signs performed in violation of Huawei's requirements
- System damages caused by customer's infrastructure problems
- To ensure the lifespan of battery cells, the firmware needs to be remotely upgraded to the latest version. The ESS must be connected to Huawei PV Cloud. Battery cell damages caused by outdated firmware due to the customer's failure to connect the ESS to Huawei's management system, which will not be covered by the warranty
- Failure to install or operate Huawei equipment, project scenarios, third-party equipment, etc. in compliance with the conditions, requirements or restrictions in Huawei solutions documents.